



Memorandum

Subject: **INFORMATION:** Work Zone Safety: Generic Crashworthy
Barricade Designs, Drums with Warning Lights, Generic
Lightweight Warning, and Lights Acceptance Letter WZ-54

Date: September 15, 2000

Original signed by
From: Frederick G. Wright, Jr.
Program Manager, Safety

Reply to
Attn. of: HSA-1

To: Directors of Field Services
Division Administrators
Federal Lands Highway Division Engineers

A) INTRODUCTION

The FHWA memorandum "INFORMATION: Crash Tested Work Zone Traffic Control Devices," dated August 28, 1998, listed work zone hardware accepted under National Cooperative Highway Research Program (NCHRP) Report 350. It also explained the revised deadline dates established by the AASHTO/FHWA Agreement. The AASHTO/FHWA agreement established October 1, 2000, as a date significant to work zone channelizing devices. This present memorandum, which will be included in our Acceptance Letters as number WZ-54, provides additional information and guidance to help highway agencies implement crash tested barricades, drums, and warning lights.

B) BARRICADES

Type one, two, and three barricades newly purchased for use on the NHS after October 1, 2000, must meet the crashworthiness guidelines contained in NCHRP Report 350 "Recommended Procedures for the Safety Performance Evaluation of Highway Features." Numerous designs have been and are being crash tested by States, FHWA pooled-fund studies, and private industry. This memorandum transmits the details of a set of "generic" steel-frame barricade designs that have been tested by a private manufacturer. The sponsor of the testing, Bent Manufacturing Company, has asked that the designs of these crashworthy barricades be distributed for use free of charge by anyone who wishes to build a NCHRP Report 350-acceptable barricade.

These barricade designs remain Work Zone Category II devices because only specific variations are permitted (in type and dimensions of reflectorized rail, gage of steel angles, and presence or absence of warning lights). (See our memorandum of July 25, 1997, and August 28, 1998 for discussion of work zone device categories. Both are on the Office of Safety Web Site). This means that any manufacturer, contractor, subcontractor, vendor, or State forces may build and/or supply these barricades and certify

that they conform to the attached designs and specifications.

By doing so they meet the requirement to supply a crashworthy device under NCHRP Report 350.

The barricades were the subject of our November 23, 1998, acceptance letter number WZ-6 to Bent Manufacturing Company. They were tested in accordance with our guidelines which call for head-on and 90-degree testing. The Type two barricade was tested using “lightweight” warning lights (the “ToughLite 2000” was the model used, with a mass of 1.3 kg). The Type III barricade was tested with two lightweight warning lights. The Type three plywood panel barricades also carried aluminum warning signs mounted on the face of the striped rails, but the sign panel caused significant windshield damage and deformation in the head-on test. Therefore, this Type three barricade should not be used with rigid signs. (See acceptance letter number WZ-40 dated June 6, 2000, for a crash-tested Type three barricade supporting a sign mounted above the top rail).

These “generic” designs were also sent to all members of the American Traffic Safety Services Association (ATSSA) on October 20, 1999.

A description and discussion of each barricade follows:

Type One and Type Two Barricade

The 914-mm wide A-frame Type two barricade was successfully crash tested. It consists of four 1156-mm long, 12 gage steel, 31.75 x 31.75-mm angle legs, each with a 14.29-mm (9/16-inch) hole at the top for bolting the two halves together and/or attaching a warning light of 1.5-kg mass or less. Four 13-mm thick plywood panels were attached to the legs using 0.635-mm bolts, nuts, and washers. The top two panels were 305-mm in width and the bottom two were 203-mm wide. This barricade is also considered acceptable when the plywood panels are 203-mm wide, or when 14 gage steel legs are used. Ballast, when used, may not be placed higher than the bottom rail (a sandbag placed on the bottom rail, or hanging from the top rails barely suspended above the pavement is acceptable). The Type two barricade may also use waffleboard plastic panels as shown in the attached specification sheets.

This same device becomes a Type one barricade when only the top rail carries reflective sheeting per the MUTCD. If a Type one barricade with no bottom rail is needed, then the legs should 12 gage steel angle. The lighter, 14 gage legs should not be used without the bottom panel as the barricade’s center of gravity and structural integrity may change, significantly altering its crash performance.

Type Three Barricade

The 2440-mm wide barricade consists of a pair of 1525-mm long, 3.5-mm thick, 38-mm x 38-mm hot rolled-high carbon steel angles as the base. To each of these is welded a 200-mm long, 51-mm square tube into which are inserted 1600-mm tall, 3.5-mm thick, 38-mm x 38-mm hot rolled high carbon steel angle uprights. The three barricade panels are each 19-mm ACX plywood and are attached with 0.9525-mm diameter bolts, nuts, and washers to each upright. The Type three barricade is also acceptable with panels that are 1830-mm or 1220-mm long.

Common Features

As mentioned above, both barricades were tested with lightweight warning lights. The Type two barricade may support one and the Type three barricade may support two such lights attached with the standard vandal resistant hardware (i.e., using the cupped washer). The metal legs/frame of these barricades may be either painted or galvanized. No additional signs or flags should be mounted on either barricade type unless tested and found to be crashworthy.

Acceptance

As discussed in Acceptance Letter WZ-6, the results of the testing met the FHWA requirements. Therefore, the devices listed in this memorandum and shown in the attached drawings are acceptable for use as Test Level 3 devices on the NHS under the range of conditions tested, when proposed by a state.

C) DRUMS WITH WARNING LIGHTS

Plastic drums with warning lights attached were considered Category II devices requiring crash testing of individual combinations. Because of successful crash testing of drums and other channelizing devices with common warning lights we now believe that most drums with Type A or C warning lights firmly affixed with vandal resistant hardware are crashworthy and may be self-certified by the vendor. The American Traffic Safety Services Association solicited information from their members on the sizes, weights, and materials used in drums and warning lights. The following table shows the range of drums and lights which are in common use and may be considered crashworthy without additional testing. A vendor may self-certify that her/his drums with lights are within the acceptable range that is considered crashworthy, or they may conduct their own “in house” crash testing to demonstrate that their drums with lights do not have the potential to severely damage the windshield of a vehicle striking the drum. The FHWA will not review test results or specifications of drums with lights that fall within the range considered crashworthy. (Note that FHWA does not advocate “live driver” crash testing. As the intent of any crash testing is to determine whether or not a device is safe, serious damage to the vehicle and/or injury to a driver may result).

CATEGORY 1 - PLASTIC DRUMS WITH WARNING LIGHTS		
	Dimensions	Typical Materials
Drums		High Density Polyethelene or Low Density Polyethelene
Mass*	4.5 kg to 7.3 kg	
Diameter	450 mm to 600 mm**	
Height	900 to 1100 mm	
Handle thickness***	13 mm	
Warning Lights		
Mass	Up to 2.4 kg	
Lens diameter	180 mm to 200 mm	
Height	270 mm to 340 mm	
Fastener Hardware	12.7 mm diameter cadmium plated steel bolt/nut and a 38.1mm diameter, 19mm high cup washer. The typical length of the bolt is 95.25 mm.	

* Ballast placed at the base is not included. Low profile ballast may be added without compromising crashworthiness.

** MUTCD Minimum “diameter” is 18” or 457-mm. Actual measurement of drums range from 305-mm for the narrow top dimension on a rectangular cross-section drum to 600-mm diameter bases.

*** Thickness of plastic handle or “ears” to which the warning light is attached. The thickness of the plastic at the point of the attachment hole should be a minimum of 8-mm.

D) LIGHTWEIGHT WARNING LIGHTS

A number of other channelizing devices (various vertical panels, barricades) have been successfully crash tested using “lightweight” warning lights. These are MUTCD Type A or C (flashing or steady-burn, respectively) lights which have a mass of 1.5 kg or less (including batteries if the lens is mounted on top of the battery case). In general, they either have a separate battery pack located at the base of the device and only the lens assembly is attached to the top of the barricade; or the lens assembly is attached to a small battery pack and the unit, including batteries, is less than 1.5 kg. The circular plastic lens is approximately 180-mm to 200-mm in diameter (nominal 7 inches). Most lightweight warning lights use LED technology.

- ! These lightweight warning lights may be considered interchangeable. That is, any channelizing device successfully crash tested with a lightweight warning light will be considered crashworthy when used with any other lightweight warning light.
- ! Channelizing devices successfully crash tested with any warning light will be considered crashworthy when used with a lightweight warning light.

- ! These lightweight light consist of a circular lens mounted on a plastic block with rounded edges. Other shapes such as thin cylindrical lights (roughly the size and shape of a flashlight) are not covered by this action as they may concentrate the impact force and penetrate a windshield.
- ! Lightweight warning lights generally conforming to this description but powered by batteries recharged by integral solar cells are also acceptable. These solar powered warning lights are limited to a mass of 1.0 kg.
- ! The standard warning light powered by two lantern batteries is not covered by this action. These standard units have a mass of approximately 2.0 kg and may not be interchanged with lightweight warning lights. However, they are acceptable when securely attached to plastic drums as discussed in the section above, and where they have been specifically included in a successful crash test and found acceptable for use.
- ! All warning lights should be securely attached to the channelizing device using standard vandal-resistant hardware as described in the table above referring to lights on drums.

E) **SUMMARY**

Please note the following provisions which apply to this letter of acceptance:

- ! Our acceptance is limited to the crashworthiness characteristics of the devices and does not cover their structural features, nor conformity with the Manual on Uniform Traffic Control Devices.
- ! Only the variations in design and materials discussed above are acceptable for devices covered by this memorandum. Any changes other than normal manufacturing tolerances will require a new acceptance letter.
- ! Should the FHWA discover that the qualification testing was flawed, that in-service performance reveals unacceptable safety problems, or that the devices being marketed are significantly different from the version considered crashworthy, it reserves the right to modify or revoke its acceptance.
- ! Manufacturers, vendors, and/or suppliers will be expected to supply potential users with sufficient information on design and installation requirements to ensure proper performance.
- ! Contractors, vendors, etc., will be expected to certify to highway agency users that the barricades, drums, warning lights, and connecting hardware furnished have essentially the same chemistry, mechanical properties, mass, and geometry as those shown in the attached drawings and specifications, and that they will meet the crashworthiness requirements of FHWA and NCHRP Report 350.
- ! Vendors supplying drums with lights under this letter must provide a self-certification of crashworthiness (a sample is attached to this memorandum). This self-certification will satisfy the requirements as a "Category 1" device under the FHWA guidelines. The FHWA will no longer write separate acceptance letters covering devices made to these specifications.
- ! To prevent misunderstanding by others, this letter of acceptance , designated as number WZ-54, shall not be reproduced except in full.

TYPE II WOOD & METAL BARRICADES

Weight: 13.2 kg (approx.)

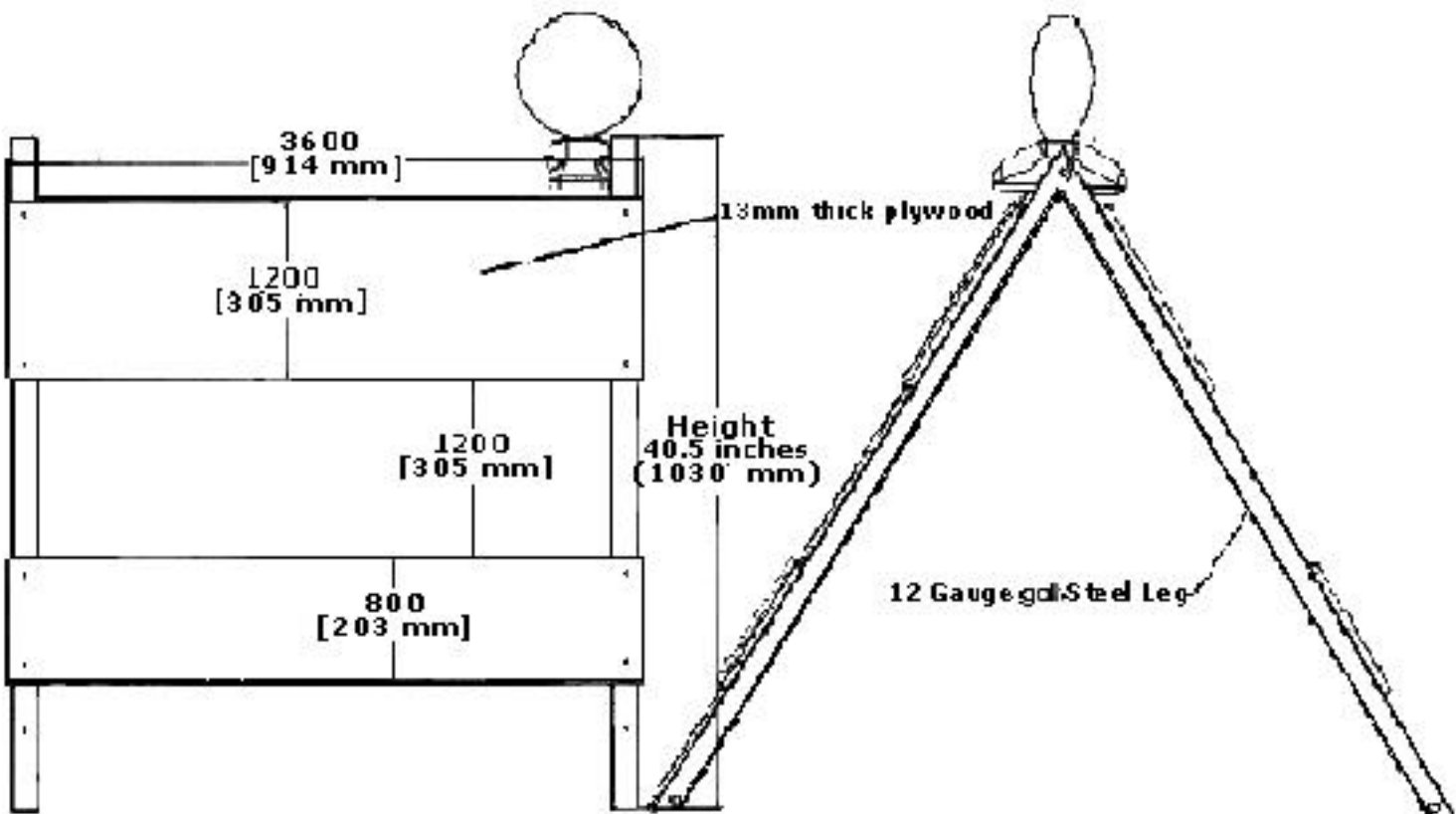

Type III Wood Barricade

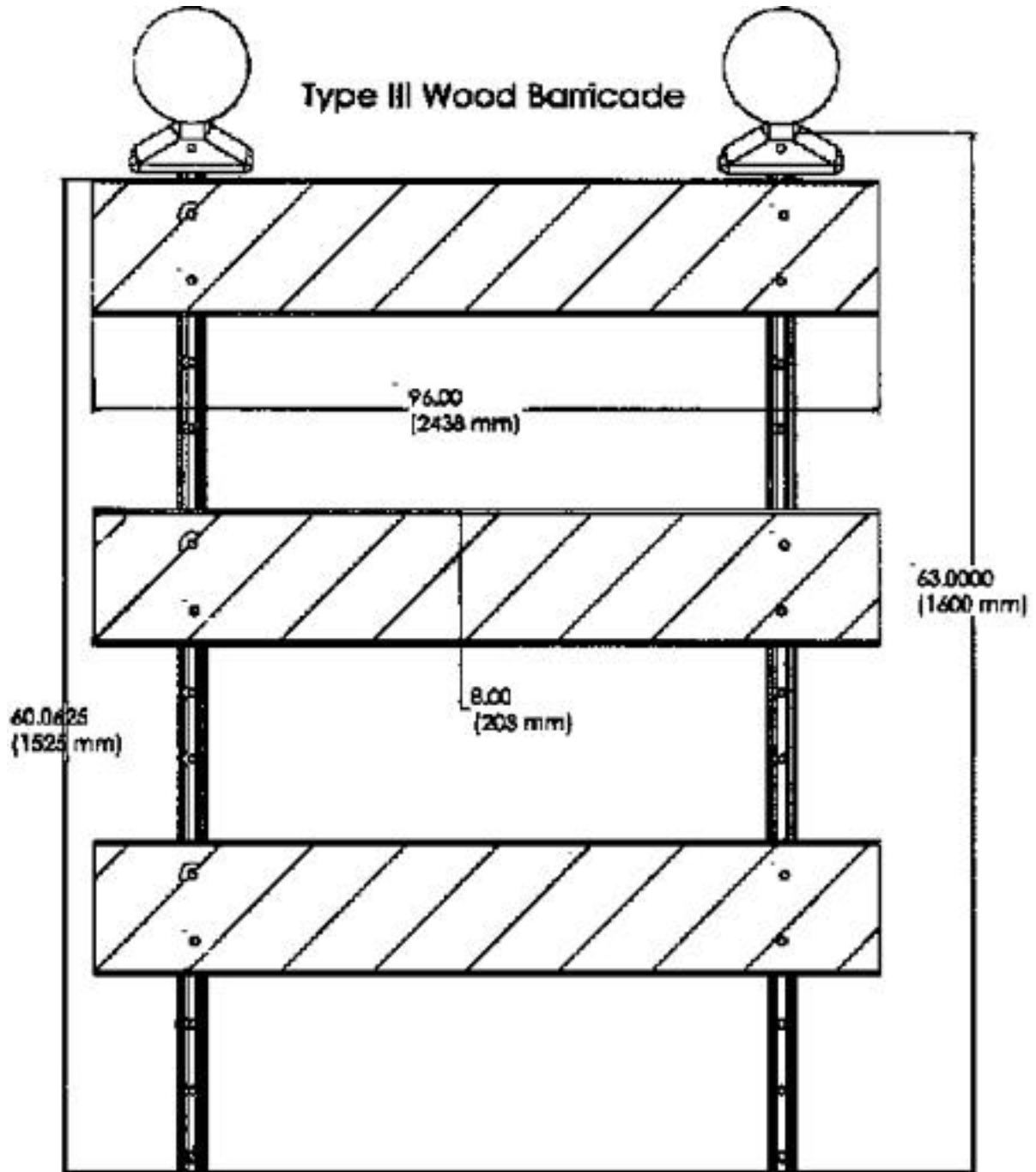

Specifications for Generic Crashworthy Barricades

Barricades	Type One or Two	Type Two	Type Three
Frame	1156 mm long, 12 ga steel angle, 31.75 x 31.75 mm "A-Frame" design 12.7 mm fasteners	1156 mm long 12 ga or 14 ga steel angle 31.75 x 31.75 mm "A-Frame" design 12.7 mm fasteners	Two 1525-mm long, 10 ga (3.5 mm thick), 38x38 mm angle bases. Uprights same except 1600 mm tall. All steel to be high-carbon, hot rolled steel.
Panels	13-mm thick plywood	13-mm thick plywood or 13-mm thick waffleboard	19-mm ACX plywood
Panel Length	914 mm	914 mm	2440 mm (or shorter: 1830mm or 1220mm)
Panel Width	203mm to 305mm	203mm to 305mm	203 mm to 305 mm
Fastener Hardware All hardware zinc plated	(Acceptance based on test of Type II barricades.)	1/4"-20 x 1" Steel Carriage Bolt, Class 1 1/4"-20 Steel Keps Lock Nut	3/8"-16 x 1 3/4" Steel Hex Bolt, Class #2 3/8"-16 Steel Hex Nut Steel flat lock washer
Height to top		1200 mm to top of light	1525 mm to top of rails
Mass		13.2 kg	30 kg
Lights (Optional)	1 lightweight	1 lightweight	2 lightweight

* The tested Type III barricade had a mass of 40.1 kg which included the lights (which are an acceptable option) and a 48x48-inch aluminum sign which is not part of the accepted barricade.

Specifications for optional "waffleboard" material for use with Generic Type One and Two Barricades

WAFFLEBOARD PLASTIC BARRICADE PANELS	
Intended Application	Type I and II Barricades
Material	High density comopolymer polyethylene with UV stabilizers
Dimensions (panel size)	6" x 24", 8" x 24", 12" x 24" Thickness: .500 (1/2 ")
Tensile strength (ASTM) D638-72	4000 PSI
Elongation 2" min % (ASTM) D38-72	600%
Flexural Modulus (ASTM) D790-71	240,000 PSI
Brittle Temperature	-180 Deg F
Softening Temperature	+320 Deg F

This is only one format that a “Certificate of Crashworthiness” might follow.

**"Certificate of Crashworthiness"
Category 1 Crashworthy Traffic Control Device(s)**

Name and address of vendor making the certification:

Unique identification number of this certificate:

Number of pages to this certificate:

Description and unambiguous identification of the item being certified: *(may refer to attached drawings or product literature. If product literature covering numerous devices is attached, the certification must spell out which models / versions are covered under this action.)*

Identification of the basis for the self certification process used and to what Test Level of NCHRP Report 350.

[There are a number of options that a vendor may choose to show evidence of crashworthiness. These include:

- 1. Refer to reports on file of crash testing that was done on his/her traffic control devices.*
- 2. Refer to an engineering analysis on file that compares his/her device to one that has been successfully crash tested.*

(The crash testing may be the simplified testing allowed by NCHRP Report 350 for work zone devices. It must show that a device poses no risk to vehicle occupants and must, as a minimum, be documented by a written report, observed by an independent, impartial observer, recorded on videotape, and include a means, other than the test vehicle's speedometer, for determining the vehicle speed at time of impact.)

- 3. Refer to the standard design, based upon crash testing, to which the device complies.*

Signature:

Title of the person(s) accepting responsibility for the content of the certificate:

Date of issue;

This certificate shall not be reproduced except in full.